

AMMONIA-DETECTOR S4022AM FOR ATEX/SIL2

Designed to meet with tough industrial requirements, the Smart-Detector allow monitoring toxic and flammable contents in harsh environments and classified areas. They offer a 8-digit back-light display and 5 mode status LED for the gas concentration reading. Ideal in harsh environments, the Smart-Detector feature non intrusive calibration for an accurate and easy adjustment via Hall-effect switches, without opening the instrument and declassifying the area. The detectors are IP 65 protected (optional IP67) and complying with SIL3 SW and SIL2 HW. As an option, the sensor is available with dual-head concept and in stainless steel construction.

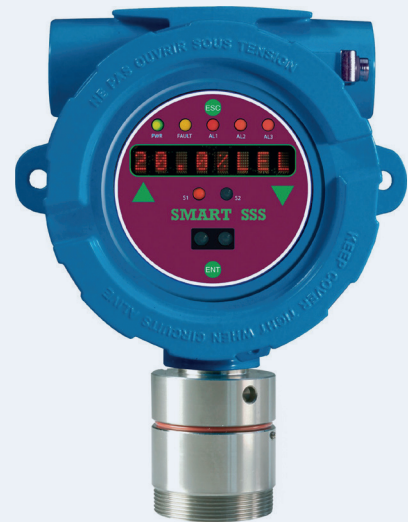

SPECIFICATIONS ELECTRONICS

SUPPLY: 24 VDC | **POWER CONSUMPTION:** max. 70 mA | **WIRING ANALOGUE/DIGITAL:** 3x0,75 mm² up to 100 m, shielded, 2x2x0,75 mm², shielded | **SIGNAL-OUTPUT ANALOGUE/DIGITAL:** 4...20 mA, Modbus RTU | **OPTIONAL RELAY OUTPUTS:** 1 or 3 | **WEIGHT:** 850...1200 gr | **CERTIFIED FOR:** SIL 2 (3) after EN50402, ATEX Group II 2G, 2GD, 3G & GD, HART-Protocol (optional)

SPECIFICATIONS SENSOR

MEASURING PRINCIPLE: Electrochemical | **MEASURING RANGE:** 0...100 ppm (Type S4008AM 0...1'000 ppm) | **ACCURACY:** +/- 2 % of measuring range | **RESPONSE TIME:** t₉₀: < 30 sec | **OPERATION TEMPERATURE:** -20 °C ...+50 °C | **HUMIDITY:** 20...90 % (non condensing) | **APPROX. LIFETIME AT 20°C:** > 2 years, depending on application | **CALIBRATION:** It is necessary to inspect the gas detector every 3 month and to recalibrate it only if needed.

DIMENSIONS AND CONNECTIONS

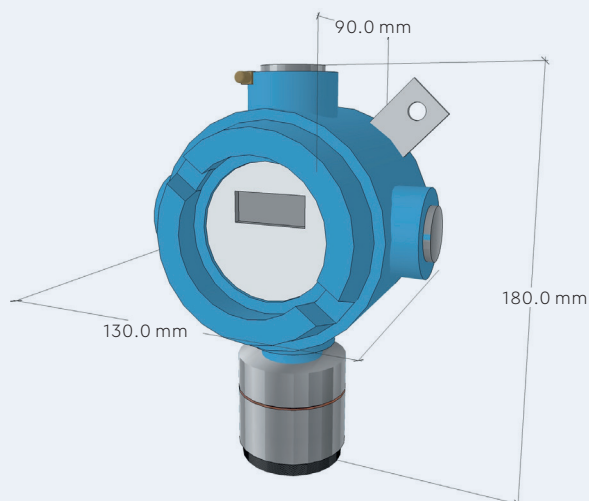

24VDC Bus1	○	○	○	○	○	○
BUS A	2	3	4	5	6	
BUS B						
0VDC						
+ Analog						
S Analog						
Ex-Gas Detector						